

## **Epson Launches High-Performance Inclinometers/ Accelerometers for Industrial Applications**

**— Combines the compactness and energy efficiency of Si-MEMS sensors with the performance of mechanical servo sensors —**

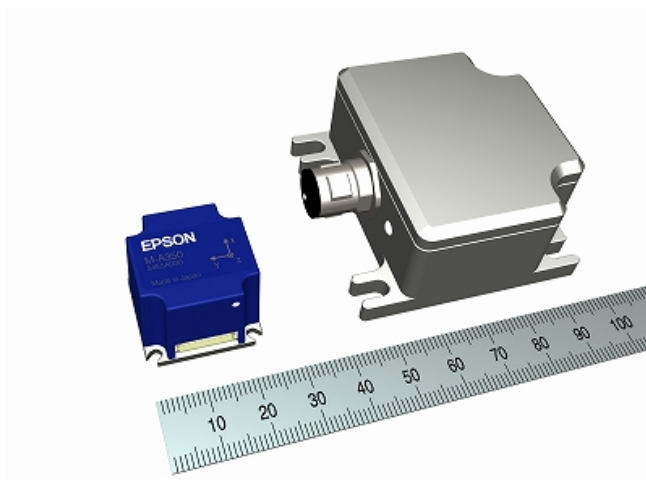

Left image: built-in unit, right: CAN unit

- Munich, Germany, November 12, 2012 –

Seiko Epson Corporation ("Epson," TSE: 6724) has developed two new compact inclinometers and two new compact accelerometers (three-axis sensor units) for different industrial applications. These products provide stable monitoring for extended periods of time with a resolution of 0.001 degree (inclinometer) and 10  $\mu$ G (accelerometer). Epson will begin shipping samples in January 2013 and plans to begin volume production within 2013.

Sensors are used in the construction and civil engineering industries to monitor horizontal and vertical planes in skyscrapers and other large structures, as well as to measure changes over time that occur in structures due to slight shaking and to measure structural distortion and deterioration after seismic activity. However, the high-precision inclinometers and accelerometers used to date for these measurements and sensing applications have been expensive, large, and heavy, characteristics that present significant barriers to adoption. Industry wanted the compactness, power-efficiency and low cost of monitoring systems provided by silicon MEMS sensors combined with the same long-lasting accuracy and stability as mechanical servo sensors.

"To meet the customer needs we drew on our unique strength in QMEMS<sup>1</sup> fabrication technology to develop a new quartz accelerometer that is both highly accurate and stable," said Toshihiko Kano, general manager of Epson's M Project. "We combined this accelerometer with semiconductor and software technology to form high-performance inclinometers and accelerometers (three-axis sensor units) for practical applications. We will supply these inclinometers and accelerometers as built-in models and as CAN<sup>2</sup>-compliant waterproof and dustproof models that can be used in a variety of applications."

These products make it easy to build a flexible monitoring system that will satisfy industrial performance requirements. They can also easily be used to realize multi-node and synchronous

measurement systems. By using a digital interface, customers will be able to build monitoring systems that have superior anti-noise performance and long-distance measurement capability in far less time.

Epson plans to demonstrate these products at the Epson booth (Hall A4, Booth #224) at Electronica 2012, an international trade fair for electronic components, systems and applications, to be held in Munich, Germany, from November 13-16.

Epson has identified sensing as an important growth business in its long-range corporate vision. The company will thus continue to leverage its crystal-based QMEMS technology in the sensing of quantities such as time, pressure, and angular velocity, driving further advances in convergence with semiconductor and software technologies, to provide customers with a wide array of solutions, including products, modules, and systems that are easy to use and that they know they can trust.

**\*1: QMEMS**

QMEMS is a combination of "Quartz," a crystalline material with excellent characteristics such as excellent frequency stability and high precision, and "MEMS" (micro electro mechanical system). QMEMS devices, produced via a microfabrication process on a quartz material instead of on a semiconductor material like MEMS, offer high performance in a compact package. QMEMS is a registered trademark of Seiko Epson Corporation.

**\*2: CAN (controller area network):** A network protocol used for automotive and industrial applications

**About Epson**

Epson is a global imaging and innovation leader whose product lineup ranges from inkjet printers and 3LCD projectors to sensors and other microdevices. Dedicated to exceeding the vision of its customers worldwide, Epson delivers customer value based on compact, energy-saving, and high-precision technologies in markets spanning enterprise and the home to commerce and industry.

Led by the Japan-based Seiko Epson Corporation, the Epson Group comprises more than 81,000 employees in 97 companies around the world, and is proud of its ongoing contributions to the global environment and the communities in which it operates.

<http://global.epson.com/>

**About Epson Europe Electronics GmbH**

Epson Europe Electronics GmbH is a marketing, engineering and sales company and the European Headquarters for electronic devices of the Seiko Epson Corporation, Japan.

Since 1989 headquartered in Munich/Germany with 60 employees, Epson Europe Electronics GmbH has several European sales representatives and has a European-wide network of distributors. Epson Europe Electronics provides value added services for Semiconductors and Quartz Devices targeted to the mobile communication, automotive and home visual market. Epson products are recognized for energy saving, low power, small form factors and rapid time to market.

Information about Epson Europe Electronics GmbH is available in the Internet under [www.epson-electronics.de](http://www.epson-electronics.de)

## Further information

### Targeted customers and main applications

- 1) Construction and civil engineering customers
  - Vibration-based structural health monitoring (e.g., monitoring the vibration characteristics of structures and judging their health and integrity)
  - Safety monitoring during construction of civil engineering structures (e.g., ensuring safety by monitoring the tilt of structures under construction)
  - Measurement of low-frequency environmental vibration, etc.
- 2) Large machines and large structures
  - Tilt measurement of ships and large machines
  - Monitoring the safety of large structures (e.g., pipelines and large plants)
- 3) Seismic sensing
  - Measurement of vibrations accompanying earthquakes (intense shocks, minor vibrations, long-period oscillation), etc.

### Product features

	Inclinometer	Accelerometer
Resolution	0.001°	10 μG
Stability	< 0.05°/year	-
Measurement range	360°	±14G
Temperature compensation	Built-in temperature compensation function	

	Built-in unit	CAN unit
Data output	SPI / UART	CAN
Dimensions	24 × 24 × 19 mm	52 × 52 × 25 mm (excluding projection)
Weight	Approx. 11g	Approx. 85g
Supply voltage	3.3 ±0.15V	9-30V
Power consumption	< 100 mW	TBD
Waterproofing / Dustproofing	None	Equivalent to IP67

Diagram 1: Incline measurement example

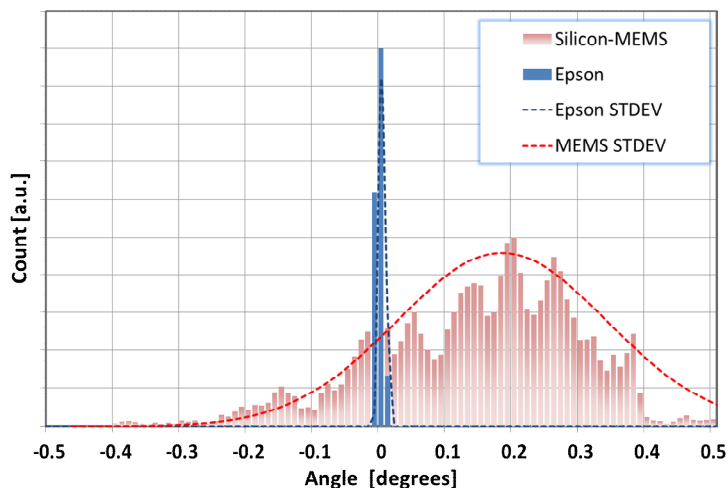

This diagram shows the distribution of measurements from inclination sensors mounted on an immovable table (incline 0°) over a two-month period.

Epson's quartz accelerometers are used in the Epson inclinometer (blue, above). Because of its high stability, it is possible to accurately measure the immovable state as displayed by an incline of 0°.

Diagram 2: Structural health monitoring example

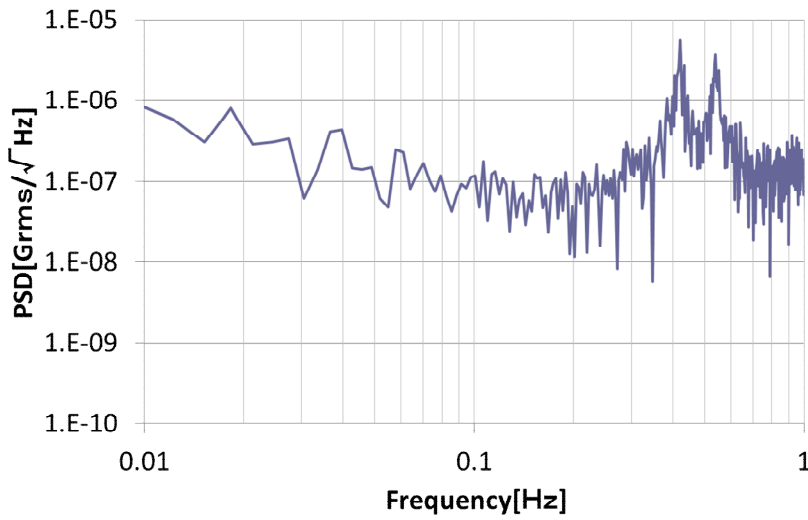

This diagram shows an example of a vibration measurement with Epson's accelerometer at a 29-story building.

It's an important tool in structural health monitoring as it precisely measures the slightest vibrations at a frequency of 0.1-1 (Hz) over a long period.

#### Further information

**Epson Europe Electronics GmbH**

**Carolin Schwan**

Marketing Communications

Riesstrasse 15

80992 München - Germany

Tel: +49-(0)89-14005-0

email: [info@epson-electronics.de](mailto:info@epson-electronics.de)

website: [www.epson-electronics.de](http://www.epson-electronics.de)