

Mini-GBIC (SFP)

1.25Gbps Gigabit Ethernet/ 1000Base-X/ Fiber Channel SFP Transceiver

- Distance: 0.5km, 2km, 10km, 40km, 60km, 80km, 120km
- Standard Operating Temperature: -10°C ~ 70°C
- Wide Operating Temperature: -40°C ~ 85°C*



OVERVIEW

Lantech 1.25Gbps Small Form Factor Pluggable (SFP) transceiver module series is specifically designed for the high performance integrated duplex data link over single-mode or multi-mode optical fiber. These transceiver modules are compliant with the SFP

Multisource Agreement (MSA). With the hot-swap ability, these modules offer an easy way to be installed into SFP MSA compliant ports at any time without the interruption of the host equipments operating online.

FEATURES & BENEFITS

- SFP Multi-Source Agreement
- Serial ID functionality support
- 1.25Gbps Gigabit Ethernet compliant
- Single +3.3V Power Supply
- LC duplex receptacle
- Class 1 laser safety standard IEC 60825 compliant
- Low power dissipation

SPECIFICATION

Absolute Maximum Ratings

Parameter	Symbol	Min.	Max.	Unit	Note
Storage Temperature	Ts	-40	+85	°C	
Supply Voltage	VccT, VccR	-0.5	4.0	V	
Storage Relative Humidity	RH	5	95	%	

Recommended Operating Conditions

Parameter	Symbol	Min.	Typ.	Max.	Unit	Note
Case Operating Temperature	Tc	-10 / -40*		70 / 85	°C	1
Supply Voltage	Vcc	3.1	3.3	3.5	V	
Supply Current	I _{tx} + I _{rx}		160	300	mA	
			160			
			180			
			180			
			180			
			180			

Notes: 1. Standard Operating Temperature / Wide Operating Temperature (-E model). *Operating Temperature of 8330-170-E is from -20°C to 85°C

Transmitter Electro-Optical Interface

Parameter	Symbol	Min.	Typ.	Max.	Unit	Note	
Transmitter Differential Input Voltage	TD +/-	400		2400	mV		
Tx_Fault - High	VFault_H	2		Vcc	V		
Tx_Fault - Low	VFault_L	Vee		Vee+0.8	V		
Tx_Disable - High	VDisable_H	2		Vcc	V		
Tx_Disable - Low	VDisable_L	Vee		Vee+0.8	V		
Optical Output Power	Po	0.5km	1	-9.5	-4	dBm	1
		2km		-9	-1		1
		10km		-9.5	-3		2
		40km		-2	+3		2
		60km		-2	+3		2
		80km		0	+5		2
		120km		0	+5		2
Optical Extinction Ratio	ER	9			dB		
Center Wavelength	λc	0.5km	830	850	860	nm	
		2km	1270	1310	1355		
		10km	1285	1310	1343		
		40km	1270	1310	1355		
		60km	1520	1550	1580		
		80km	1520	1550	1580		
		120km	1520	1550	1580		
Spectral Width	Δλ	0.5km			0.85	nm	
		2km			4		
		10km			2.8		
		40km			1		
		60km			1		
		80km			1		
		120km			1		
Optical Rise / Fall Timet	tr / tf			260	ps	3	
Total Contributed Jitter	TJ			227	ps		

Notes: 1. Coupling into a 50/125μm multimode fiber. 2. Coupling into a 9/125μm single-mode fiber. 3. 20% to 80% value

Receiver Electro-Optical Interface

Parameter	Symbol	Min.	Typ.	Max.	Unit	Note	
Receiver Differential Output Voltage	RD +/-	400		2000	mV		
Receiver Overload	PINMAX	0.5km				1	-3
		2km					-1
		10km					-3
		40km					-2
		60km					-1
		80km					-1
		120km					-9
Receiver Sensitivity	PINMIN	0.5km			dBm	1	-17
		2km					-19
		10km					-20
		40km					-23
		60km					-23
		80km					-24
		120km					-30
Operating Center Wavelength	λc	0.5km	770		nm		860
		2km	1260				1620
		10km					
		40km					
		60km					
		80km					
		120km					
Receiver Loss of Signal - TTL Low	PRX_LOSD	0.5km			dBm		-17.5
		2km					-19
		10km					-20
		40km					-23
		60km					-24
		80km					-24
		120km					-30
Receiver Loss of Signal - TTL High	PRX_LOSA	-35			dBm	-45 for 120km	
Receiver Loss of Signal - Hysteresis	PRX_LOSH	0.5			dB		

Notes: 1. With BER better than or equal to 1×10^{-12} , measured in the center of the eye opening with $2^7 - 1$ PRBS

MTBF

	60% Confidence Level, 25°C		90% Confidence Level, 25°C	
	MTBF	FIT	MTBF	FIT
0.5km	813526	1229	325410	3073
2km	813526	1229	325410	3073
10km	813526	1229	325410	3073
40km	813526	1229	325410	3073
60km	813526	1229	325410	3073
80km	813526	1229	325410	3073
120km	813526	1229	325410	3073

DIMENSIONS (unit=mm)

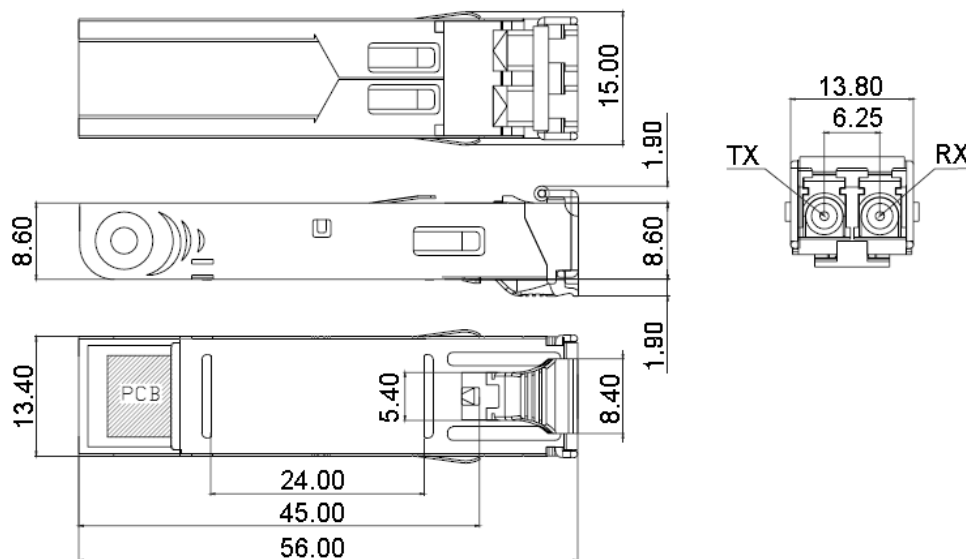

*All dimensions are ±0.2mm unless otherwise specified

ORDERING INFORMATION

Part Number	Wavelength	LD	IO	LOS	Mode	Link	Temp.
8330-162	850 nm	VCSEL	AC/AC	TTL	Multi-mode	550m	-10-70°C
8330-163	1310 nm	FP				2km	-10-70°C
8330-165	1310 nm	FP				10km	-10-70°C
8330-166	1310 nm	DFB			Single-mode	40km	-10-70°C
8330-169	1550 nm	DFB				60km	-10-70°C
8330-167	1550 nm	DFB				80km	-10-70°C
8330-170	1550 nm	DFB				120km	-10-70°C

Part Number	Wavelength	LD	IO	LOS	Mode	Link	Temp.
8330-162-E	850 nm	VCSEL	AC/AC	TTL	Multi-mode	550m	-40-85°C
8330-163-E	1310 nm	FP				2km	-40-85°C
8330-165-E	1310 nm	FP				10km	-40-85°C
8330-166-E	1310 nm	DFB			Single-mode	40km	-40-85°C
8330-169-E	1550 nm	DFB				60km	-40-85°C
8330-167-E	1550 nm	DFB				80km	-40-85°C
8330-170-E	1550 nm	DFB				120km	-20-85°C

Lantech Communications Europe GmbH

www.lantechcom.eu / www.lantechcom.tw
info@lantechcom.eu

© 2009 Copyright Lantech Communications Global Inc. all rights reserved.
The revise authority rights of product specifications belong to Lantech Communications Global Inc.
Lantech may make changes to specification and product descriptions at anytime, without notice.