

MDA16-2i/-4i/-8i

D/A converter modules for PCI-BASEII, PCIe-BASE

Assemble measurement card. Control. Analog.

For optimum customization to a measurement application, the PCI/PCIe cards from BMC Messsysteme GmbH can be supplemented with various modules. The short latency of the PCI/PCIe interface makes the MDA16-2i/-4i/-8i modules especially attractive for controlling tasks.

2, 4 or 8 analog outputs. 16 bit. $\pm 10V$.

The MDA16-2i/-4i/-8i precisely emits analog signals with 16-bit resolution in the $\pm 10V$ range. They are available at the 37-pole Sub-D female connector of the PCI/PCIe card. Depending on the version, 2, 4 or 8 analog outputs are provided.

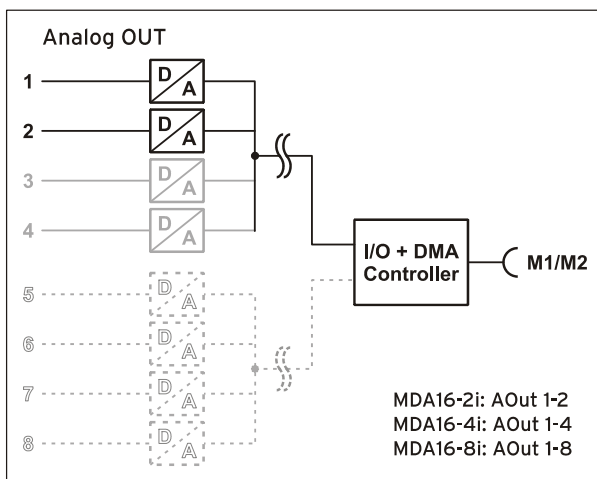

Functional diagram



Clearly safe.

The galvanic isolation of the analog outputs from the PC ground provides interference-free operation and protects DAQ system and PC against high potentials.

Function generator.

The MDA16-2i/-4i/-8i features a function generator, which outputs various signals (sine wave, rectangle, or ramp function). Signal amplitude ($\pm 10V$) and frequency (max. 100kHz) are programmable via software.

Modularity. Individuality. Flexibility.

A great variety of analog input modules, analog output modules or CAN modules is available to equip the PCI/PCIe base board for a measurement application.

The free combinability of the modules in the two card slots creates individual solutions.

1 Installation on the PCI-BASEII, PCIe-BASE

The MDA16-2i/-4i/-8i module can be integrated on any slot of the *PCI-BASEII*, *PCIe-BASE* or older versions. Make sure the plugs and sockets fit together exactly.

If using both an MAD and an MDA16-4i or MDA16-2i module, the best solution is to plug the MAD on slot M1 and the output module on slot M2. In this way, all analog inputs and outputs are available at the Sub-D 37 female connector of the PCI/PCIe card.

The channels of the module on slot M2 can be accessed at the internal pin connectors K3, K4 of the DAQ card. They can be led out of the PC using the *ZUKA16* connection cable (connect channel 1 (colored line) of *ZUKA16* with pin 1 of the pin connector K3 (square pad), attach 2. connector in parallel).

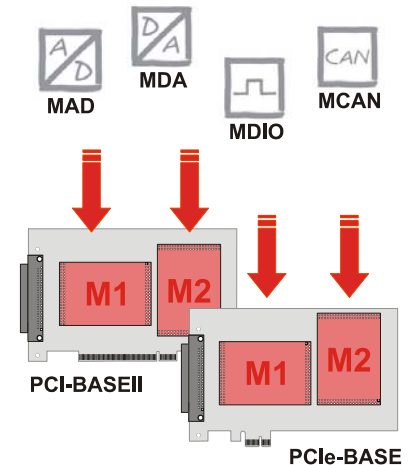

- **If the modules are not plugged correctly, the modules and/or the DAQ card may be damaged!**
- **The modules are electrostatic sensitive devices - please provide for a conductive pad connected to ground during installation.**
- **The channels of slot 2 are only available at the Sub-D37 connector of the DAQ card if the relevant solder jumpers on the base board have been configured correctly (see relating data sheet).**
- **Leading the outputs of an MDA16-2i/-4i/-8i mounted on slot M2 to the Sub-D37 female of the DAQ card is not possible if using former versions of PCI cards from bmc.**

2 Addressing the MDA16-2i/-4i/-8i modules

The address configuration is done via the 3-pole solder jumpers PL1-3 on the (component-free) bottom side of the module board.

The MDA16-2i/-4i/-8i module is preset to address 2. The addresses 6 and 7 are reserved.

Address	0	1	2	3	4	5
PL1						
PL2						
PL3						

Address 2 is factory setting

The address determines the assignment of the channels. For example, the MDA16-4i module (4 outputs) with the lower address is assigned to the channels 1-4, the other module to the following channels.

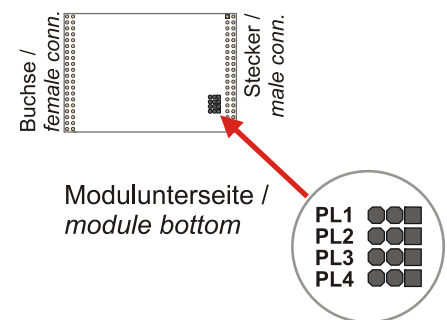

If using two modules (also of different type), two different addresses must be assigned!

3 Pin assignment of the MDA modules with the PCI/PCIe card

The following tables show which pins are used for the connection of the analog outputs, depending which slot the MDA module is plugged on or if the connector cable ZUKA16 is used.

MODULE SLOT M1		OUTPUT MODULE			MODULE SLOT M2	
Sub-D37 PCI(e)-BASE	Plug/Pin PCI(e)-BASE	MDA16-2i	MDA16-4i	MDA16-8i	Sub-D37 ZUKA16	Plug/Pin PCI(e)-BASE
1	K1/1	AOut 1	AOut 1	AOut 1	1	K3/1
2	K1/3	AOut 2	AOut 2	AOut 2	2	K3/3
3	K1/5	-	AOut 3	AOut 3	3	K3/5
4	K1/7	-	AOut 4	AOut 4	4	K3/7
5	K1/9	-	-	AOut 5	5	K3/9
6	K1/11	-	-	AOut 6	6	K3/11
7	K1/13	-	-	AOut 7	7	K3/13
8	K1/15	-	-	AOut 8	8	K3/15
9	K1/17	-	-	-	9	K3/17
10	K1/19	-	-	-	10	K3/19
11	K2/1	-	-	-	11	K4/1
12	K2/3	-	-	-	12	K4/3
13	K2/5	-	-	-	13	K4/5
14	K2/7	-	-	-	14	K4/7
15	K2/9	-	-	-	15	K4/9
16	K2/11	-	-	-	16	K4/11
17*	K2/13	-	-	-	17	K4/13
18*	K2/15	-	-	-	18	K4/15
19*	K2/17	-	-	-	19	K4/17
20	K1/2	AGND	AGND	AGND	20	K3/2
21	K1/4	AGND	AGND	AGND	21	K3/4
22	K1/6	-	AGND	AGND	22	K3/6
23	K1/8	-	AGND	AGND	23	K3/8
24	K1/10	-	-	AGND	24	K3/10
25	K1/12	-	-	AGND	25	K3/12
26	K1/14	-	-	AGND	26	K3/14
27	K1/16	-	-	AGND	27	K3/16
28	K1/18	-	-	-	28	K3/18
29	K1/20	-	-	-	29	K3/20
30	K2/2	-	-	-	30	K4/2
31	K2/4	-	-	-	31	K4/4
32	K2/6	-	-	-	32	K4/6
33	K2/8	-	-	-	33	K4/8
34	K2/10	-	-	-	34	K4/10
35	K2/12	-	-	-	35	K4/12
36*	K2/14	-	-	-	36	K4/14
37*	K2/16	-	-	-	37	K4/16

* assignment changes if analog channels of the 2nd slot are led through (see chapter 1)

4 Important notes for using the MDA16-2i/-4i/-8i

- The modules are only suitable for extra-low voltages - please observe the relevant regulations! The modules must only be used in closed PC housings (for reasons relating to EMC).
- All accessible pins are electrostatic sensitive devices. Provide for a grounded conductive work place.
- For cleaning only use non-solvent detergents. The product is designed to be maintenance-free.
- The product must not be used for safety-relevant tasks. With the use of the product, the customer becomes manufacturer by law and is therefore fully responsible for the proper installation and use of the product. In the case of improper use and/or unauthorized interference, our warranty ceases and any warranty claim is excluded.
- Improper installation of the modules on the PCI/PCIe card may damage the modules and/or the DAQ card.
- To remove the module, first loosen it on one plugged side by levering the module with the utmost caution using a blunt object (e.g. plastic ballpoint pen). Then carefully lift up the other side with your hand moving it back and forth.
- Exposing the card to strong vibrations requires additional protection of the module.
- If connecting internal ribbon cables to the PCI/PCIe base board, please make sure the modules are well ventilated to prevent excess heating. Also observe the temperature ranges of the PC.



Do not dispose of the product in the domestic waste or at any waste collection places. It has to be either duly disposed according to the WEEE directive or can be returned to bmcm at your own expense.

5 Technical data

(typical at 20°C, after 5min.)

• Analog outputs

Channels:	2 (MDA16-2i), 4 (MDA16-4i) or 8 (MDA16-8i) outputs, galvanically isolated from the PC
Resolution:	16 bit
Relative accuracy:	0.0015%
Converter rate:	10µs
Output range:	±10V
Function generator:	sine wave, ramp, rectangle, programmable via software (Libad4 or NextView®4.4), max. ±10V, 100kHz
Zero shift:	max. ±50ppm/°C
Gain drop:	max. ±50ppm/°C
Output current:	max. 10mA
Settling time:	max. 10µs
R _{out} :	51Ω
Error in the relevant range:	max. ±4 LSB
Noise in the relevant range:	max. ±4 LSB

The values for accuracy always relate to the respective output range. Errors might add at worst.

• General data

Power supply:	+4.5V..+5.5V from PCI-BASEII or PCIe-BASE, max. 300mA
CE standards:	EN61000-6-1, EN61000-6-3, EN61010-1; for decl. of conformity (PDF) visit www.bmcm.de
ElektroG // ear registration:	RoHS and WEEE compliant // WEEE Reg.-No. DE75472248
Max. perm. potentials:	60V DC acc. to VDE , max. 1kV ESD on open lines
Temperature ranges:	operating temp.: -25°C..+50°C, storage temp.: -25°C..+70°C
Relative humidity:	0-90% (not condensing)
Dimensions:	~ 74 x 52 x 13 mm ³
Delivery:	product, description
Warranty:	2 years from date of purchase at bmcm, claims for damages resulting from improper use excluded