

678 480

Bi-Face mini Vor- und Rückwärtsentgrater aus Hartmetall - 90°

Mini Carbide Forward / Backward Deburrer

[DE]: Mini Vor- und Rückwärtsentgrater aus VHM. Lange Ausführung mit beidseitig geschliffenem Kopf. Zum Entgraten, Fasen und Rückwärtsentgraten auch an schwer zugänglichen Stellen. Winkel 90°. Oberfläche X.Cut beschichtet.

[EN]: Mini Carbide deburring tool for front / back deburring and chamfering. Long version for difficult access. Chamfering angle 90°. With X.Cut coating.

ST 500	ST 800	ST 1000	ST 1300	54 HRC	62 HRC	68 HRC	INCOX < 900	INCOX > 900	Ni / Co	Titan	GG	GGG / GT	Aluminium	ANSI < 10	ANSI > 10	Cu	Plast	Grafit
□	□	□	□	□	□	□	□	□	□	□	□	□	□	□	□	□	□	□

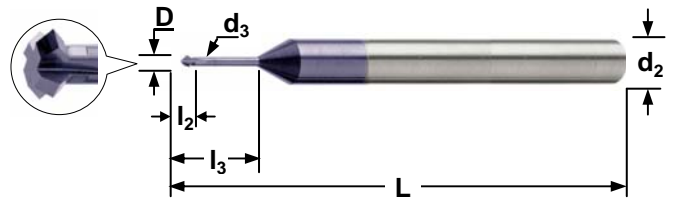

Ø	Ø	Ø	T	L	L2	L3	z	Art.No.
D _{+0,+0,05}	d ₂ h6	d ₃ max	max	+1/-1	min	min	=	
1,00	3	0,7	0,30	60	0,50	5	3	678.480-0100
1,50	3	1,1	0,45	60	0,73	6	3	678.480-0150

Ø	Ø	Ø	T	L	L2	L3	z	Art.No.
D _{+0,+0,05}	d ₂ h6	d ₃ max	max	+1/-1	min	min	=	
2,00	3	1,5	0,60	60	0,95	8	3	678.480-0200
3,00	3	2,1	0,90	60	1,50	10	3	678.480-0300

668 480

678 480 jedoch unbeschichtet
678 480 without coating

ST 500	ST 800	ST 1000	ST 1300	54 HRC	62 HRC	68 HRC	INCOX < 900	INCOX > 900	Ni / Co	Titan	GG	GGG / GT	Aluminium	ANSI < 10	ANSI > 10	Cu	Plast	Grafit
□	□	□	□	□	□	□	□	□	□	□	□	□	□	□	□	□	□	□



details: www.toolgate.de/668480

[DE] Multifunktional Senken und Entgraten

- konstant hinterschliffenes Profil
- bestens geeignet für Schlichtbearbeitung
- horizontale Bearbeitung oder Interpolation
- Vor-/Rückwärtsentgraten von Bohrungen
- mehr Leistung durch hochpräzisen Schliff für höchste Oberflächengüten

[EN] Multifunctional Chamfering and Deburring

- constantly relief profile
- well suited for finishing operations
- forward- and backward deburring of holes
- better performance due to high precision grinding for improved depthing and surface finish

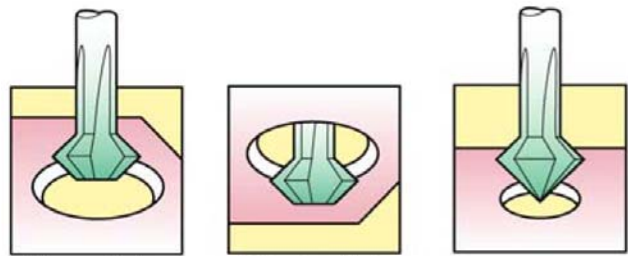

Vorwärts
Forward

Rückwärts
Backward

Senken
Chamfering

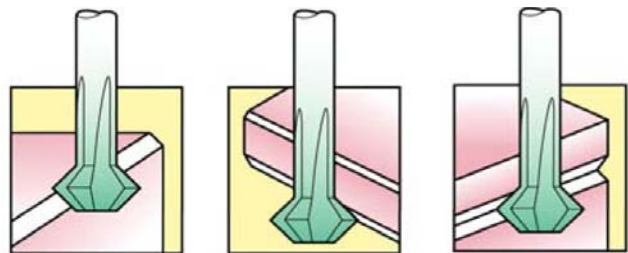

Fasen
Beveling

Rückfasen
Backward Beveling

V-Nut Fräsen
V-Grooving

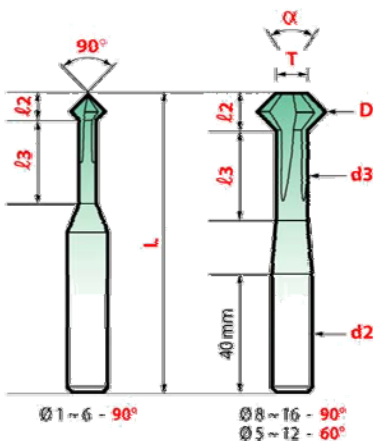

Toleranzen
Tolerances

	D	L	d2	α
Ø 1 ~ 5	0 - 0,05	±1	h6	±1°
Ø 6 ~ 16	0 - 0,10			

678 490

Bi-Face Vor- und Rückwärtsentgrater aus Hartmetall - 90°

Carbide Forward / Backward Deburrer

[DE]: Vor- und Rückwärtsentgrater aus VHM. Lange Ausführung mit beidseitig geschliffenem Kopf. Zum Entgraten, Fasen und Rückwärtsentgraten auch an schwer zugänglichen Stellen. Winkel 90°. Oberfläche X.Cut beschichtet.

[EN]: Carbide deburring tool for front / back deburring and chamfering. Long version for difficult access. Chamfering angle 90°. With X.Cut coating.

ST 500	ST 800	ST 1000	ST 1300	54 HRC	62 HRC	68 HRC	INOX < 900	INOX > 900	Ni / Co	Titan	GG	GGG / GT	Aluminium	ASI < 10	ASI > 10	Cu	Plast	Grafit
<input type="checkbox"/>	<input type="checkbox"/>	<input type="checkbox"/>	<input type="checkbox"/>	<input type="checkbox"/>	<input type="checkbox"/>	<input type="checkbox"/>	<input type="checkbox"/>	<input type="checkbox"/>	<input type="checkbox"/>	<input type="checkbox"/>	<input type="checkbox"/>	<input type="checkbox"/>	<input type="checkbox"/>	<input type="checkbox"/>	<input type="checkbox"/>	<input type="checkbox"/>	<input type="checkbox"/>	<input type="checkbox"/>

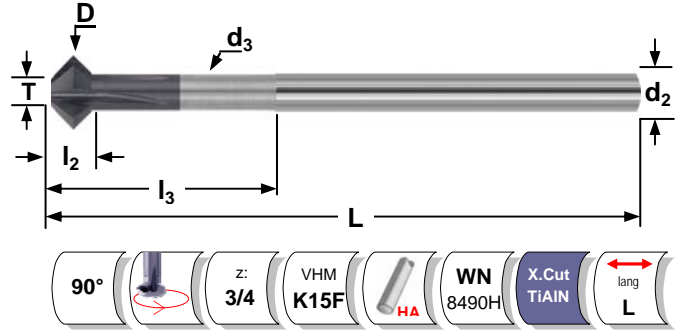

∅	∅	∅	T	L	l2	l3	z	Art.No.
D _{+0,+0,05}	d2 h6	d3 max	max	+1/-1	min	min	=	
1,80	6	1,5	-	100	1,20	8	3	678.490-0180
2,80	6	2,0	-	100	1,30	9	3	678.490-0280
3,00	6	2,2	1,2	100	1,30	10	4	678.490-0300
4,00	6	2,9	1,6	100	1,75	12	4	678.490-0400
5,00	6	3,4	2,0	100	2,30	15	4	678.490-0500

∅	∅	∅	T	L	l2	l3	z	Art.No.
D _{+0,+0,05}	d2 h6	d3 max	max	+1/-1	min	min	=	
6,00	6	3,8	2,4	100	2,90	18	4	678.490-0600
8,00	6	4,9	4,9	100	3,0	34	4	678.490-0800
10,00	6	5,9	5,9	100	4,0	34	4	678.490-1000
12,00	6	5,9	5,9	100	6,0	34	4	678.490-1200
16,00	10	7,9	7,9	100	8,0	34	4	678.490-1600

668 490

678 490 jedoch unbeschichtet
678 490 without coating

ST 500	ST 800	ST 1000	ST 1300	54 HRC	62 HRC	68 HRC	INOX < 900	INOX > 900	Ni / Co	Titan	GG	GGG / GT	Aluminium	ASI < 10	ASI > 10	Cu	Plast	Grafit
<input type="checkbox"/>	<input type="checkbox"/>	<input type="checkbox"/>	<input type="checkbox"/>	<input type="checkbox"/>	<input type="checkbox"/>	<input type="checkbox"/>	<input type="checkbox"/>	<input type="checkbox"/>	<input type="checkbox"/>	<input type="checkbox"/>	<input type="checkbox"/>	<input type="checkbox"/>	<input type="checkbox"/>	<input type="checkbox"/>	<input type="checkbox"/>	<input type="checkbox"/>	<input type="checkbox"/>	<input type="checkbox"/>

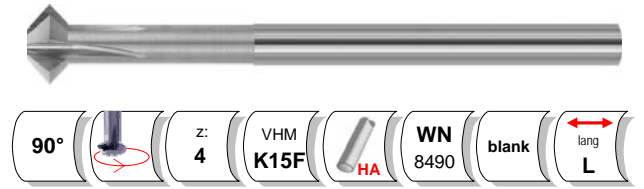

details: www.toolgate.de/668490

678 460

Bi-Face Vor- und Rückwärtsentgrater aus Hartmetall - 60°

Carbide Forward / Backward Deburrer

[DE]: Vor- und Rückwärtsentgrater aus VHM. Lange Ausführung mit beidseitig geschliffenem Kopf. Zum Entgraten, Fasen und Rückwärtsentgraten auch an schwer zugänglichen Stellen. Winkel 60°. Oberfläche X.Cut beschichtet.

[EN]: Carbide deburring tool for front / back deburring and chamfering. Long version for difficult access. Chamfering angle 60°. With X.Cut coating.

ST 500	ST 800	ST 1000	ST 1300	54 HRC	62 HRC	68 HRC	INOX < 900	INOX > 900	Ni / Co	Titan	GG	GGG / GT	Aluminium	ASI < 10	ASI > 10	Cu	Plast	Grafit
<input type="checkbox"/>	<input type="checkbox"/>	<input type="checkbox"/>	<input type="checkbox"/>	<input type="checkbox"/>	<input type="checkbox"/>	<input type="checkbox"/>	<input type="checkbox"/>	<input type="checkbox"/>	<input type="checkbox"/>	<input type="checkbox"/>	<input type="checkbox"/>	<input type="checkbox"/>	<input type="checkbox"/>	<input type="checkbox"/>	<input type="checkbox"/>	<input type="checkbox"/>	<input type="checkbox"/>	<input type="checkbox"/>

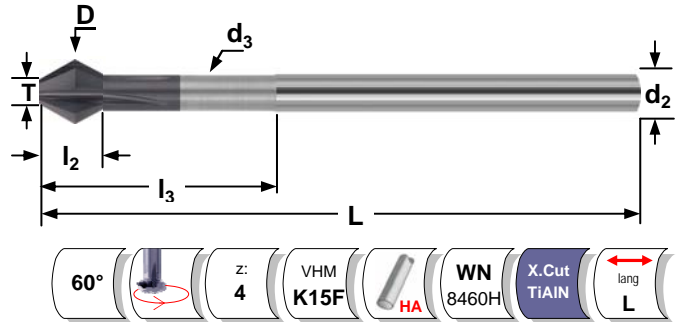

∅	∅	∅	T	L	l2	l3	z	Art.No.
D _{+0,+0,05}	d2 h6	d3 max	max	+1/-1	min	min	=	
5,00	6	3,4	3,4	100	2,8	34	4	678.460-0500
8,00	6	4,9	4,9	100	5,4	34	4	678.460-0600

∅	∅	∅	T	L	l2	l3	z	Art.No.
D _{+0,+0,05}	d2 h6	d3 max	max	+1/-1	min	min	=	
12,00	6	5,9	5,9	100	10,6	34	4	678.460-1200

668 460

678 460 jedoch unbeschichtet
678 460 without coating

ST 500	ST 800	ST 1000	ST 1300	54 HRC	62 HRC	68 HRC	INOX < 900	INOX > 900	Ni / Co	Titan	GG	GGG / GT	Aluminium	ASI < 10	ASI > 10	Cu	Plast	Grafit
<input type="checkbox"/>	<input type="checkbox"/>	<input type="checkbox"/>	<input type="checkbox"/>	<input type="checkbox"/>	<input type="checkbox"/>	<input type="checkbox"/>	<input type="checkbox"/>	<input type="checkbox"/>	<input type="checkbox"/>	<input type="checkbox"/>	<input type="checkbox"/>	<input type="checkbox"/>	<input type="checkbox"/>	<input type="checkbox"/>	<input type="checkbox"/>	<input type="checkbox"/>	<input type="checkbox"/>	<input type="checkbox"/>

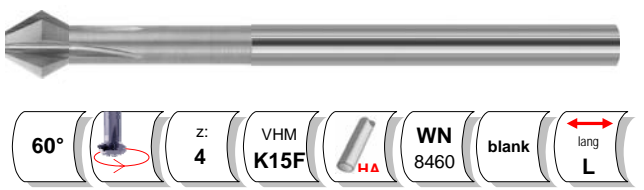

details: www.toolgate.de/668460