



Paris, France, January 14, 2014

ESI is the pioneer and world-leading solution provider in virtual prototyping.

Market Data

Listed in compartment C of NYSE Euronext Paris

[ISIN FR 0004110310](#)

Contact

[ESI Group](#)

Céline Gallerne

T: +33 (0)1 41 73 58 46

Celine.Gallerne@esi-group.com

Visit our Press Room

www.esi-group.com/newsroom

Connect with ESI



EUROPEAN UNION

The EnE-HVAC project is financed by the European Union



ESI participates in European Project directed at energy saving technologies

A joint research project to develop energy efficient HVAC components

Paris, France – January 14, 2014 – [ESI Group](#), pioneer and world-leading solution provider in [Virtual Prototyping](#) for manufacturing industries, announces the development of new simulation technologies to achieve more energy efficient [heating, ventilation and air conditioning systems \(HVAC\)](#). This research activity will take place as part of the [EnE-HVAC](#) project, granted by the European Commission under the [Seventh Framework Program](#).

Heating, Ventilation, and Air Conditioning (HVAC) systems account for approximately 35% of the total energy consumption in residential and commercial buildings. Although today most of the energy consumed is spent on heating, there is an increasing demand for cooling solutions. The demand is expected to escalate in the coming years due to climate change. To reduce overall energy consumption, the European Commission has identified a compelling need to seek new and innovative technologies able to increase the efficiency of HVAC systems.

With this in mind, the European Commission funded the [EnE-HVAC](#) project that was launched in October 2012. The project is expected to enable the achievement of significant energy savings in future HVAC systems through use of new and innovative technologies. These technologies include nano-technological coatings and surface treatments for improved heat transfer; new nano-materials and micro-materials for improved efficiency of the refrigerants; and, improved efficiency and heat transfer capabilities of coolants via new nano-technological additives.

The [ESI](#) research team based at the CFD & Multiphysics Center of Excellence in Essen, Germany is working on the development of new methodologies for [Computational Fluid Dynamics](#) (CFD) and Multiphysics applications, particularly focusing on coupling multidisciplinary software tools.

Using the ESI advanced CFD & Multiphysics solution, the [ACE+ Suite](#), ESI team is developing nano-technology simulation approaches for modeling

specific parts of HVAC components, including anti-freezing / anti-ice surfaces, condensation drainage systems, evaporation systems and heat transfer systems.

*“A well-orchestrated synergy between simulation and experimental tests helps reduce the number of physical experiments needed as part of the [EnE-HVAC project](#),” says project coordinator **Jacob Ask Hansen** from the Danish Technological Institute. “Running multiple iterations of synthesis and surface manufacturing followed by laboratory tests require numerous man hours. By using initial experimental input from small scale tests and feeding this information into large scale numerical models, we gain extremely valuable input for selecting optimal surfaces for large scale physical tests. This iterative process between experiments and modeling is very valuable for getting the most accurate end results in shorter time scales”.*

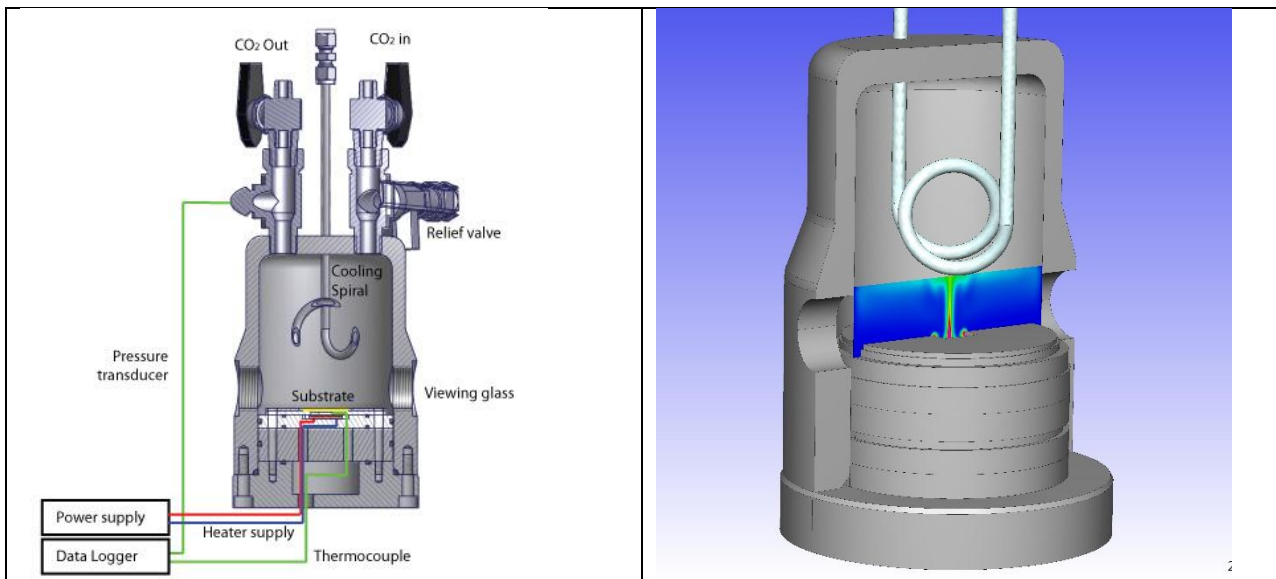

***Image:** Test facility used by the Danish Technical Institute to measure improved heat transfer of nanostructured substrates (left); corresponding simulation results obtained from ACE+ Suite (right).*

The project engages a consortium consisting of 8 European partners, including 6 industry partners (LuVe S.p.a. (Italy), EXHAUSTO A/S (Denmark), ESI GmbH (Germany), Dansk Varmepumpe Industri A/S (Denmark), Carbodeon Ltd. Oy. (Finland) and Vahterus Oy (Finland) and, two research institutions (the Danish Technological Institute, (Denmark), and IK4 Tekniker, (Spain)).

For more news or information about the En-HVAC project, please visit www.ene-hvac.eu

For more news or information about ESI’s CFD & Multiphysics solution ACE+ Suite, please visit www.esi-group.com/ACE-Suite

For more news or information about ESI solutions, please visit www.esi-group.com



About ESI Group

[ESI](#) is a pioneer and world-leading provider in Virtual Prototyping that takes into account the physics of materials. [ESI](#) boasts a unique know-how in Virtual Product Engineering, based on an integrated suite of coherent, industry-oriented applications. Addressing manufacturing industries, Virtual Product Engineering aims to replace physical prototypes by realistically simulating a product's behavior during testing, to fine-tune fabrication and assembly processes in accordance with desired product performance, and to evaluate the impact on product use under normal or accidental conditions. [ESI's](#) solutions fit into a single collaborative and open environment for End-to-End Virtual Prototyping. These solutions are delivered using the latest technologies, including immersive Virtual Reality, to bring products to life in 3D; helping customers make the right decisions throughout product development. The company employs about 1000 high-level specialists worldwide covering more than 40 countries. [ESI Group](#) is listed in compartment C of NYSE Euronext Paris.

Connect with ESI on [LinkedIn](#), [Twitter](#), [Facebook](#), and [YouTube](#)

ESI Group – Media Relations

[Céline Gallerne](#)

T: +33 (0)1 41 73 58 46